



April 1993

Contributors:

Steve Bloom	John Dittmeier
Helen Goodell	Bob Jacoby
Clyde Payton	Bill Robertson
Tico & Maggi Rubio	Roger & Carol Stuart

The Florida Clinker Breaker

FABA MEMBERSHIP DUES DUE MAY 1st

submitted by Roger & Carol Stuart, FABA Treasurers

In the upper right corner of your mailing label is the date of your membership expiration. If your label reads, "Member Through 4/30/93" then your \$15 dollar membership fee is due on May 1st. If you joined FABA after January 1993, your membership is extended through until 4/30/94. Unfortunately, if you joined late in 1992, your membership still expires 4/30/93. These details are all spelled out in the fine print on the membership application. This seems to be the most fair way to manage the membership because of the administrative complexities of any other system.

Please make your checks out to the "Florida Artist Blacksmith Association" (FABA) and send to:

Roger & Carol Stuart
FABA Treasurers
Star Route 1, Box 207
Crescent City, FL 32112

SCHOLARSHIPS

by Maggi Rubio, chairperson

Clay Spencer has offered members of FABA a \$200 tuition scholarship for a one week blacksmithing class at John C. Campbell Folk School which is good until January 1994. He has only one stipulation: he wants it to go to someone who has never taken a class at JCCF's before. The scholarship committee

continued on page 8

PRESIDENT'S MESSAGE

by Tico Rubio, FABA President

It's hard to believe that once again plans are being finalized for this year's state conference in October. Bill Roberts has some great people lined up for us and classes are starting to take shape. Ann Reynolds has the family program well under control and it looks like, as always, it will be bigger and better than ever before. It's time to start thinking about individual and area group projects for the auction, especially with the warm weather about to encompass us. Remember, there's only one

continued on page 8

ABOUT THE "WITS" OF FABA -

by Maggi Rubio

In a mad euphoric moment in January at the quarterly state meeting in West Palm Beach, I decided it would be a great idea if the women made a quilt together to be raffled off at this year's state conference. Not only did I convince the board to allow \$300 for expenses, Mary Brandenburg offered to print the tickets, at no expense, on one of the Brandenburgs' computers. Within moments, the creative juices were flowing between all the women, and ladies started volunteering to make a square for the quilt, even if they didn't sew!!! I was thrilled!

Wen I got back to Barberville (Tico was still shaking his head), reality oozed back into my being (now I finally understood why my husband was shaking his head every time he looked at me,

continued on page 8

Upcoming Events

- APR 3 **NE Regional Meeting:** Steve Bloom's Shop - Archer, Florida; Part III of knifemaking series (see preview and map in this issue)
- APR 10 **Statewide Meeting** - Clyde Payton's Shop near Monticello, FL (preview and map in this issue)
- APR 17 **SE Regional Meeting:** Ray & Anne Reynolds shop - West Palm Beach, FL (map in this issue)
- APR 23 - 24 Morningside Nature Center, Gainesville, FL - Annual Farn 'n Forest Festival (preview in this issue)
- APR 24 **SW Regional Meeting** and Crowley Museum & Nature Center Silver Jubilee - Crowley Museum - Sarasota, FL (preview & map in this issue)
- MAY 1 **NE Regional Meeting** - Tico Rubio will host the meeting at Barberville, FL (map in this issue)
- NW Regional Meeting:** No meeting in May - see you in Madison!
- MAY 14 - 15 **ABANA Southeastern Regional Conference** - Madison, GA
- MAY 15 **SE Regional Meeting:** Contact Ray Reynolds, SE Region Program Coordinator
- MAY 29 **SW Regional Meeting:** Crowley Museum - Sarasota, FL
- JUNE 5 **NE Regional Meeting** - Walt Anderson
- JUNE 12 **NW Regional Meeting:** Sam Atkins Park near Blountstown, FL - brick forge work day
- JULY **NE Regional Meeting** - Ronnie Fowler
- AUG 14 **NW Regional Meeting:** Dr. Ed & Nancy Crane's shop - Tallahassee, FL
- SEPT 11 **NW Regional Meeting:** Ben Ferguson's shop - Freeport, FL
- SEPT 10 - 12 Alabama Forge Council Annual Conference, Tanneyhill State Park (West of Birmingham, AL)
- OCT 9 **State Wide Conference:** Barberville, FL
- NOV 13 **NW Regional Meeting:** Dr. Skeeter & Lou Prather's shop in Tallahassee, FL.

The calendar includes events of interest to the blacksmithing community. Florida Artist Blacksmith Association (FABA) sponsored events are highlighted in bold typeface. The regions have no boundaries - everyone is welcome everywhere. Come to more than one if you can. We hold regular monthly meetings in each region (except that we all try to get together at one Statewide Meeting each quarter) on the following Saturdays of each month: NE-1st, NW-2nd, SE-2rd, SW-last. The actual dates may vary from month to month; check the schedule below. We also hold short board meetings at the quarterly statewide meetings, and a board meeting and general membership meeting at the annual conference. Our meetings are informal gatherings around the forge. Prospective members are always welcome, come for all or any part of a meeting, bring your tools, or just watch. Most meetings run from 9AM to 4PM, and you'll need lunch if you stay all day, unless otherwise noted. If you have any questions about meetings please contact the Regional Coordinators listed below:

Northeast:	Steve Bloom	(904) 528-6508 h; (904) 392-7279 w
Northwest:	Clyde Payton	(904) 997-3627 h; (904) 488-0577 w
Southeast:	Ray Reynolds	(407) 793-2452 h
Southwest:	Lewis Riggelman	(904) 521-3515 h; (813) 942-5454 w

not to scale

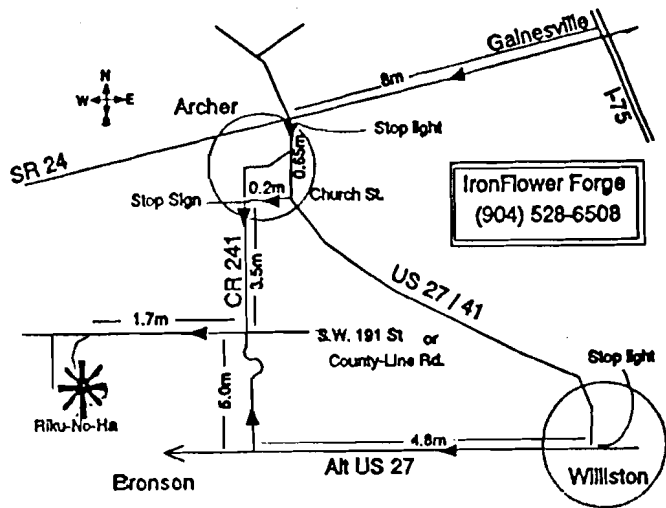

NE Regional Meeting
 April 3, 1993 9:00
 Steve & Kimmy Bloom
 (904) 528-6508 home
 (904) 392-7279 work
 Archer, Florida

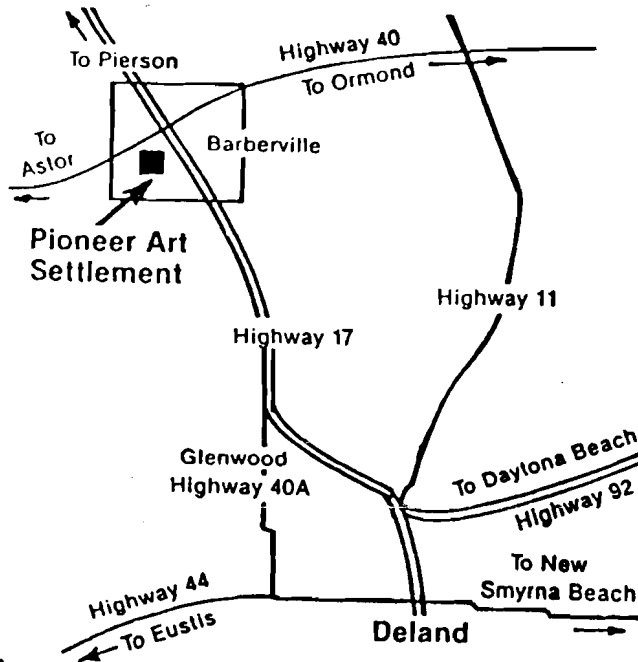

NE Regional Meeting
 May 1, 1993 9:00 AM
 Tico & Maggi Rubio
 (904) 749-3327

How To Get To The CROWLEY MUSEUM
 SARASOTA, FLORIDA
 I-75 IS SUGGESTED IF POSSIBLE

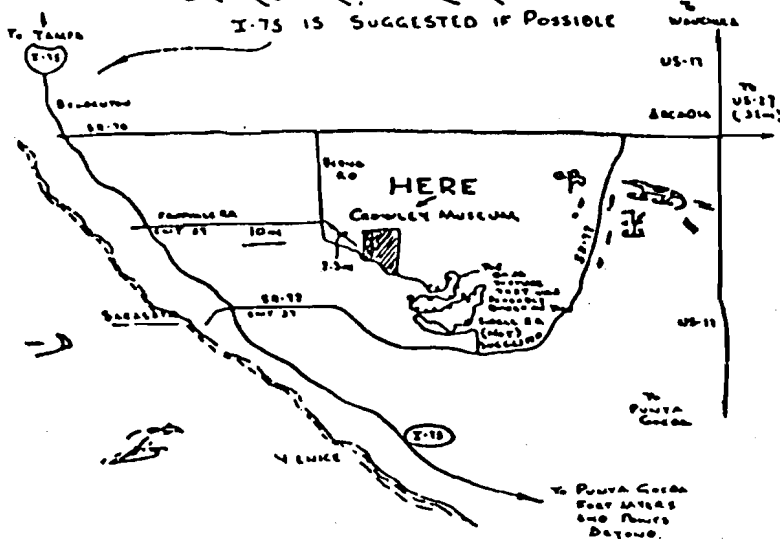

SW Regional Meeting
 March 27, 1993 10:00 AM
 April 24, 1993 10:00 AM
 Dale Kipp (813) 747-6743
 Crowley Museum (813) 747-6743
 16404 Myakka Road, Sarasota

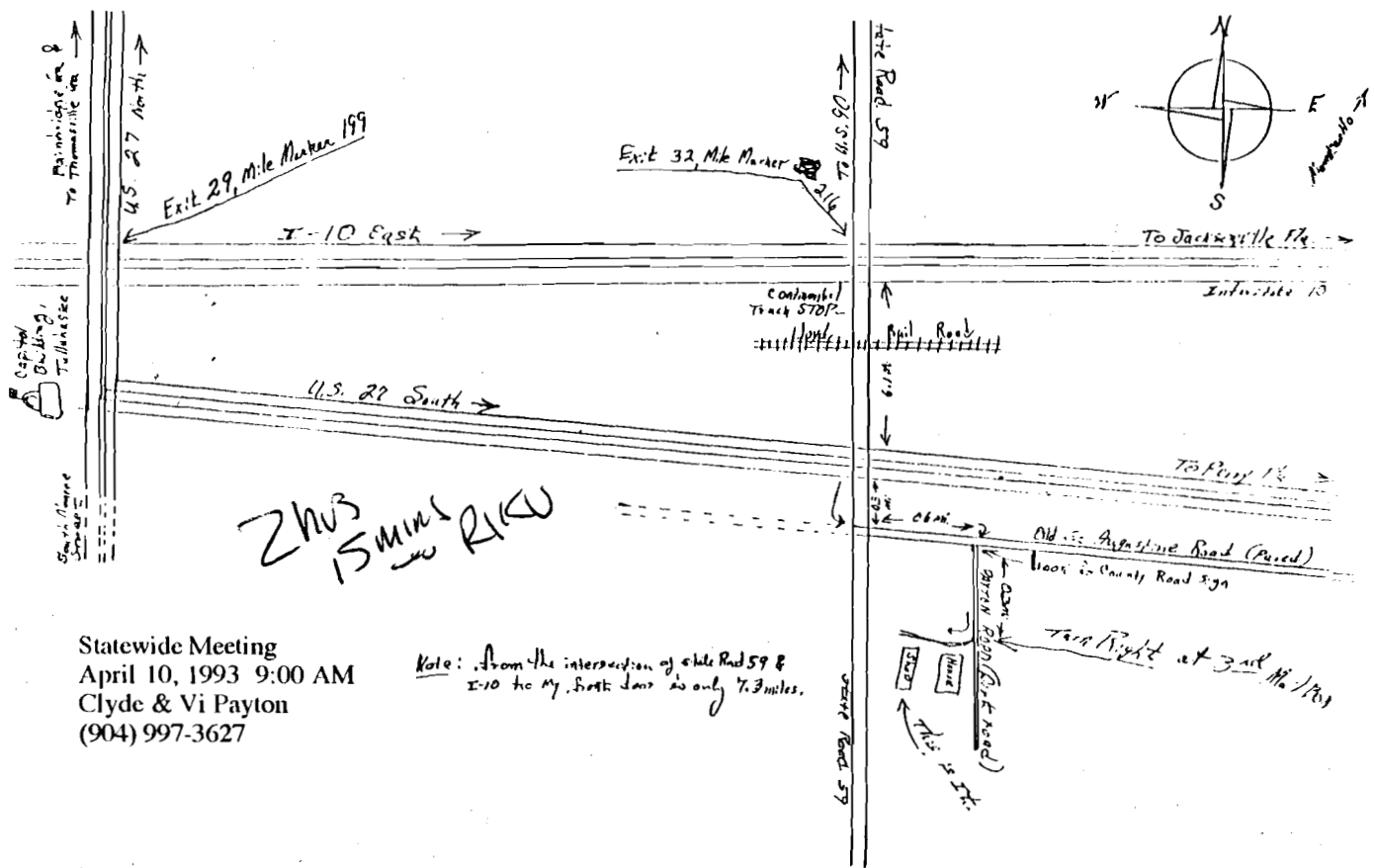

Statewide Meeting
 April 10, 1993 9:00 AM
 Clyde & Vi Payton
 (904) 997-3627

Note: From the intersection of State Road 59 & I-10 to my South Lane is only 7.3 miles.

* Reynolds
 11064 Sunset Blvd. (last house on the right)
 793-2452

Exit I-95 (or Turnpike @ N Palm Beach) at Okeechobee Blvd, West. Head west to Royal Palm Beach Blvd. (no sign at intersection) look for Barnett & Shell. Head north (right) to Sunset Blvd. (about 4 miles). Turn right on Sunset. We're the last house on the right.

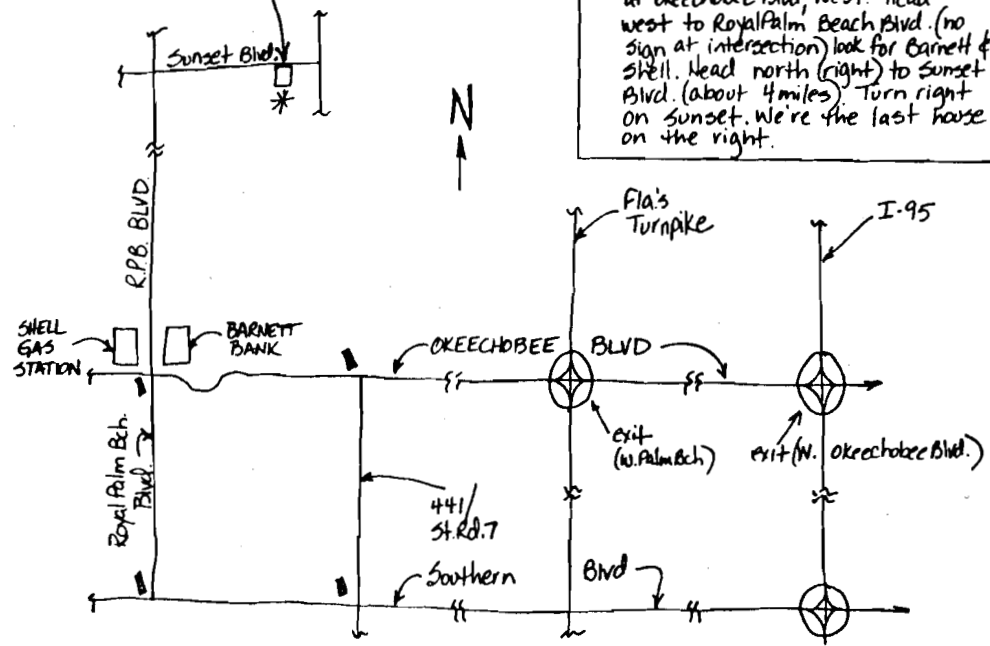

SE Regional Meeting
 April 17, 1993 9:00 AM
 Ray & Anne Reynolds
 (407) 793-2452

Clyde Payton

APRIL NE MEETING PREVIEW

The Northeast Region's April meeting will be held at Steve and Kimmy Bloom's shop in Archer Florida. This meeting will feature the final of the Northeast Region's three part knifemaking series. Ronnie Fowler will cover knife finishing including torch burning the blade slot in the bolster (the junkyard guard) andommel (butt cap) installation. Steve will probably have examples ofommel that he's designed in wax and manufactured using investment casting.

The knife making series promises to be a real treat because often times the only thing that is ever demonstrated is billet welding. While welding is a critical skill, there are many facets of successful knifemaking. If you've got any interest in bladesmithing, be sure not to miss this series.

Lunch will be provided; bring chairs! If you've ever wondered where good blacksmiths go when they die, you can get a preview by visiting Steve and Kimmy's shop. Hope to see you there.

APRIL STATEWIDE MEETING PREVIEW

Clyde Payton, Program Coordinator for the Northwest Region

The April Statewide Meeting will be held on the second Saturday, April 10, 1993 at Clyde & Vi Payton's blacksmith shop near Monticello, Florida. Lunch will be furnished, but feel free to bring a covered dish and cold drinks if you wish. Free camping is available on site, also motels are nearby. You're welcome to come a day early and/or stay an extra day and work in the Payton's shop if you desire.

Jerry Grice and Bill Roberts will be demonstrating. Jerry is going to demonstrate how to do gold leaf on forged iron. He will first forge out a free standing floor lamp and show us how gold leaf is used by applying it to certain parts. The floor lamp is going to be a group project, therefore come prepared to do some work. The lamp will be donated to the auction at the October State Conference at Barberville.

Bill Roberts is going to demonstrate how to do aluminum leaf, copper leaf, and brass leaf on forged iron and forged non-ferrous metals. As you may know, Bill is an accomplished jeweler and runs his own CUSTOM DESIGNS shop. He does some very beautiful work.

You are encouraged to bring your own portable forge and tools to set up along side if you wish. Also, we encourage you to bring items for the TAILGATE SALES area. Bring a donation for the BUCK-IN-THE-BUCKET drawing. Finally, there will be a short business meeting at noon.

A map to Clyde & Vi's shop is in this issue. So, there you have it! This is going to be a great meeting so please don't miss it.

FARM 'N FOREST FESTIVAL

April 23rd and 24th Morningside Nature Center in Gainesville will be presenting the 15th Annual Farm 'n Forest Festival. Friday, April 23rd, (10AM to 3PM) will be primarily for groups of school children and Saturday the 24th, (10AM to 4PM) will be for the general public. This Festival will explore turn of the century farm life and crafts through demonstrations and will also celebrate Earth Day with conservation exhibits and activities.

FABA members are invited to share their vision of Florida's past and future by participating in the Farm 'n Forest Festival. If you'd like to be one of the demonstrating artisans or just be added to the Morningside Nature Center's mailing list please call Alycin Hayes, Event Coordinator at (904) 334-2170.

APRIL SOUTHWEST REGION PREVIEW

Helen Goodell, Crowley Board of Directors

The CROWLEY MUSEUM & NATURE CENTER will be celebrating its SILVER JUBILEE on Saturday, April 24th, which is the regular monthly meeting date.

Members of FABA and their families are invited to join the festivities, which will include special exhibits of the Crowley and other local pioneer families, a petting lot of farm animals for the youngsters, special exhibits, a SAVE THE PANTHER presentation which will include a female panther and her 3 month old cub; hayrides and Joe's famous chicken barbecue lunch.

No reservations are necessary except for the Barbecue, which will sell at cost for under \$3. Reserve with FABA past president Lou Riggleman @ (904) 521-3515 II; (813) 937-4281 W. FABA members are free to sell their crafts at this meeting.

FARM DAY 1993 - SUCCESS!

Roger & Carol Stuart hosted Heifer Project International's Farm Day 1993 at their farm in Crescent City Florida on February 20th. Roger reports that over 500 people attended the event including FABA members Walt & Peggy Anderson, Thurmond & Sadie Chaffin, Bob Jacoby and his 3 year old daughter Cameron. Thurmond Chaffin demonstrated blacksmithing all day at Roger's forge and is purported to have hand forged an entire mini van which he then drove home! How's that for some fancy forge work?

MADISON CONFERENCE ACCOMMODATIONS

The Madison Travelodge, (404) 342-7800, is giving us a special conference rate of \$29 / Night for rooms with 1 queen or 2 double beds. All the demonstrators and many other attendees will be staying there so in addition to being a good deal, it's a great opportunity to mingle with fellow blacksmiths!

AROUND THE MODERN SMITHY, CIRCA 1993

By John Dittmeier

The past ten years have seen interesting developments in the low technology of the American smithy. For the most part, the progress derives from historic methods that went unrecognized and from modern industry which was yet discovered. In the 1970's, the new smiths occupied themselves with issues that were a continuation of the traditional rural smithy: salvage steel, quality of soft coal, brick forges, control of the air blast, restoration of anvil faces, and the like. The need to produce for income may have been a spur to evolve more useful equipment; just the breadth of talent in the contemporary smithing community was sure to generate new ways of working hot steel. This is one smith's observation of current events. May more modern smiths add to the parade.

CUSTOM CAST STEEL ANVILS

It is my understanding that the farrier suppliers were the first to approach the foundries. The market for new anvils apparently grew to a level that regional groups of smiths, such as FABA in Florida, have contracted for quantity purchases of anvils. Their faces receive a heat treatment for hardening.

SHEET STEEL CHIMNEYS WITH VENTURI

The first wide-spread publicity came when a fabricator placed his steel chimneys at every coal forge of ABANA's 1990 Conference in Alfred, New York. In 1991, FABA's own Roger Stuart demonstrated his chimney. Years earlier, the Anvil's Ring had a cover page and article on a stone and mortar version. It is truly amazing to see soot, smoke and flames fly horizontally into the chimney's base opening.

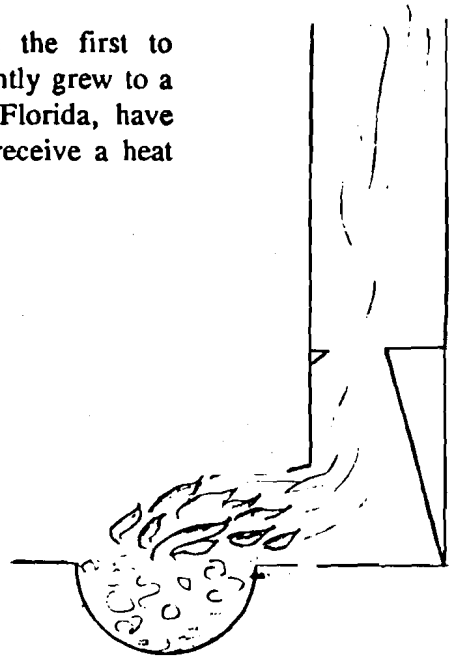

FOOT-POWERED TREADLE HAMMER

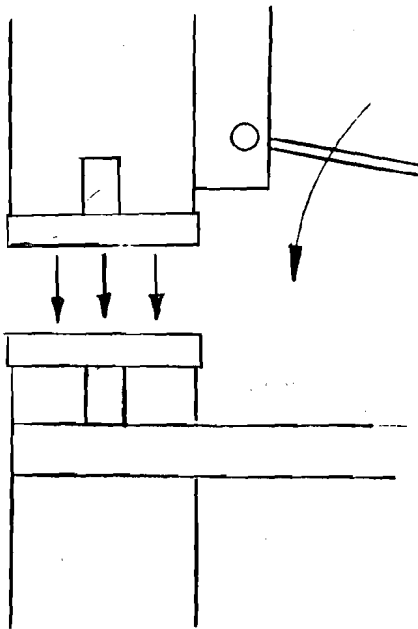

Two smiths, Paul Marx and Gary Gade, revealed their version at the 1984 ABANA Conference in DePere, Wisconsin and later donated a design pamphlet to the ABANA office for revenue sale. Then, Clay Spencer added his modifications for adjusting the hammer height and for adding top and bottom tools. FABA smiths are now making portable treadle hammers that bolt together, that have an opening in the anvil for drift pins and that use 1 x 4 inch bars for a fabricated anvil and hammer. However, olivers, as the British call them, date back several centuries. The U.S Patent Office has 80 inventions for foot-powered forging.

TRIP AIR HAMMER

It was at the 1987 Southeast Regional Blacksmithing Conference in Madison, Georgia that the two North Carolina fellows revealed their power hammer of welded steel body and one moving part: a compressed air piston connected to the hammer billet. Its 1/2 inch plate steel base requires bolting to a floor of concrete or of timbers but otherwise does not need a foundation. The blow is about 35 pounds in Little Giant terms. It should run from an 5 horsepower, 18 cubic feet per minute air compressor. A recent Anvil's Ring carried a photograph of a homemade version.

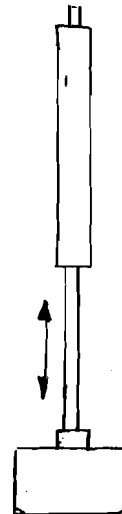

HANS PEOT CIRCULAR FURNACE

This man was the program director for the B-1 bomber and now uses his engineering mind on smithing equipment. Using 1 inch thick ceramic wool inside a steel tube of 8 or 10 inch diameter, the smith has a ready, efficient, affordable heat source. The tube need not be a heavy steel pipe. The propane burner is just as simple and is atmospheric, i.e., blowerless. The ends are stacked fire brick. What is attractive is that the burner can be moved to other furnaces of different diameter or length. Being so lightweight, the furnace becomes mobile in the shop and available at different forging stations.

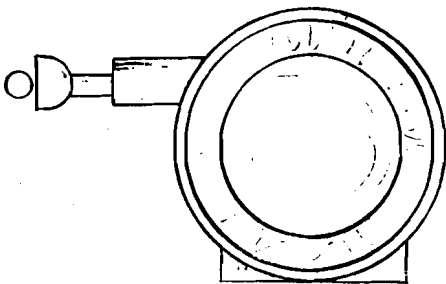

SANDIA LABORATORY RECUPERATIVE FURNACE

Rob Gunter led us out of the wilderness with his modern propane forge. Although costly in time and materials, it does effectively consume the oxygen while the door is closed and reaches high welding temperatures with its reflective, soft refractory.

KNIFE BILLET WELDING FURNACES

Master knivemakers Al Pendray and Steve Schwarzer have, by the empirical method, now have furnaces with big-time BTU ratings for the purpose of forge welding Damascus steel billets. The air blast volume and the propane pressure are accordingly higher. Inside the furnace's steel pipe is a layer of ceramic wool as insulation around the inner poured hard refractory.

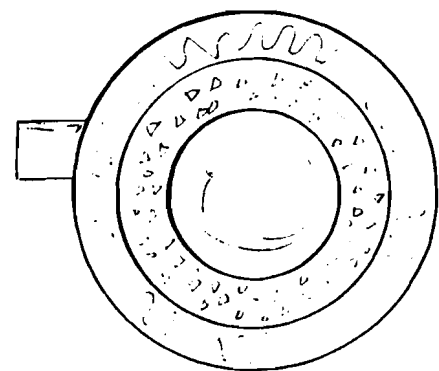

LOW COST BAND SAWS AND DRILL PRESSES

Visit the local import tool store to purchase an horizontal bandsaw for \$165.00. But do not overheat the electric motor. Drip cutting fluid or oil on the kerf. Invest in \$15.00 saw blades.

HYDRAULIC PRESS

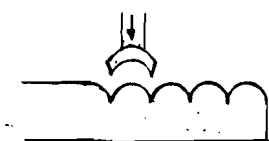

I think that this piece of equipment will be the next wave of forging. The press squeezes and pushes the hot steel in a way that we have not seen before. Yet presses have been in use for some time. More later on this piece of equipment.

PRESIDENT'S MESSAGE

continued from page 1

more quarterly state meeting after this one in April at Clyde's in Tallahassee, so if you have any ideas you want to present, please try to come to the quarterly or get in touch with your area rep so they can get it to Bill or me, or call me with your thoughts and I'll present them.

Because our conference keeps getting bigger and bigger, it seems we never have enough volunteers. We have lots of jobs that need to be done, before conference and during. Some are big and require a lot of effort, but most are small and require only an hour or two of your time. It's a great way to meet other members and make new friends. If you can give this association some of your time or experience, or maybe some muscle, please let Bill or me know so we can utilize your talents.

I'm researching the possibilities of having a Sandia Forge workshop. The last one that Walt Anderson was responsible for was such a success, people have been asking for another. If this is of interest to you, let me know.

ABOUT THE "WITS" OF FABA -

continued from page 1

well, partly anyway), and I thought, "What have you done to yourself now, Hon?". Not one to be undone by a challenge, I bought the fabric, washed and ironed it, cut it into blocks, wrote a letter, and started addressing these "surprises" to everyone I knew, who I was pretty sure wouldn't physically harm me for including them in this venture without permission. As it turned out, only one woman sent one back, and did so quickly so I could give it to someone else, with a letter of apology. So, once again I became inspired and decided that all these ladies needed a name that stood for cooperation, guts, spirit, and dedication. Hence, all women of FABA who contribute effort to this year's state conference, no matter what they do (now you can tell I'm gonna' need you again, huh?) will be part of WITS - WOMEN INVOLVED TOGETHER SUCCESSFULLY.

Thank you, ladies, from the bottom of my heart! I couldn't pull this off without you.

SCHOLARSHIPS

continued from page 1

also has certain stipulations and/or requirements and even a surprise. The surprise is that the FABA board has allocated \$300 to cover travel expenses and lodging which makes the opportunity cost free to the recipient. If you are interested in applying for this scholarship, please send a note to Mary Brandenburg for an application. A decision will be made sometime after the quarterly meeting in April, so it's important to send for that application NOW!!!!!!

The following two items are available to anyone who wants them. The scholarship committee feels that these are more awards than scholarships so there are no restrictions on these. If more than one person wants to take advantage of each event, a name will be drawn.

- 1) APRIL 24-25, 1993 OZARK REGIONAL CONFERENCE, Potosi, MO. Offer: Conference fee and meal tickets. This requires pre-registration so get in touch with Mary Brandenburg fast. (For this award you must be an ABANA member - this is their requirement, not the FABA scholarship committees).
- 2) SEPTEMBER 10-12, 1993 ALABAMA FORGE COUNCIL, Tanneyhill State Park. Offer: Free Registration. These folks would like the recipient to donate something to their auction. Again, please drop a line to Mary if interested.

The members of the scholarship committee are Carol and Roger Stuart, Mary Brandenburg, and Maggi Rubio. We will have a complete update at the quarterly state meeting in April at Tallahassee. Requests for scholarship applications should be directed to:

Mary Brandenburg
Scholarship Committee
299 Granada Road
West Palm Beach, FL 33401

NW NEWS - Blacksmithing in a Blizzard

by Patty Draper and Bill Robertson

They don't call them the mighty, mighty blacksmiths for nothing. Over a dozen smiths braved snow, downed trees and power lines to attend the hammer-in at Applecross Forge on March 13, 1993, dramatically staged the morning following the passage through Florida of the "storm of the century." Subject to correction by the ol' timers, this group claimed it to be the first FABA hammer-in conducted during snowfall.

Widespread electric power outages rendered Applecross devoid of modern blacksmithing conveniences -- arc welders, grinders, chop saws, toilets -- yet, to the immense satisfaction of all involved, a productive day of blacksmithing was achieved.

With the aid of a manual post drill and Willard Smith, who somehow broke free of his ABANA southeastern Regional Conference ("Madison conference") responsibilities for a day, Bill Robertson's portable forge blower was repaired. Especially entertaining were everyone's many attempts to use power tools throughout the day. Patty Draper and Virgil Mayo achieved a forge weld on a metal part once owned by Virgil's father with only the light of the forge to guide them.

continued next page

Bill's famous chili and brownies and a huge bonfire provided heat for those not able to edge up to one of the three forges which burned throughout the day.

Following Patty's demonstration of the Francis Whitaker twisting wrench, Jeff Valentine turned out one with which his son Thomas quickly twisted up some railroad spikes. Jeff also turned out the prettiest hot chisel of the day.

The Bar C boys, Bryant and D.J. Comer, teamed up to produce a spring fuller under Bill's tutelage. Other mighty smiths in attendance were Dr. Ed Crane, Tom Long, Al Jones, J.C. Hawkins and Clyde Payton.

ANVIL SHOOT CHALLENGE

Colonel Tim (Bulls Eye) Ryan challenges all safe and sober anvil shooters to meet him in honest anvil shooting competition at the 1993 Alabama Forge Council Conference to be held September 10 - 12, 1993 at Tanneyhill State Park due West of Birmingham, Alabama.

During the 1992 Alabama Forge Council Conference Colonel Ryan is alleged to have pierced the eye of a bull's-eye located just five feet from the anvil's point of origin. The anvil is said to have traveled to unprecedented heights during its trip from launching anvil to aforementioned "bull" eye.

Universal stock support for Sandia Gas forges

1/2" round stock in a 'V' shape, welded to 1/2" upright, which in turn is welded to a plate which slides on the rails

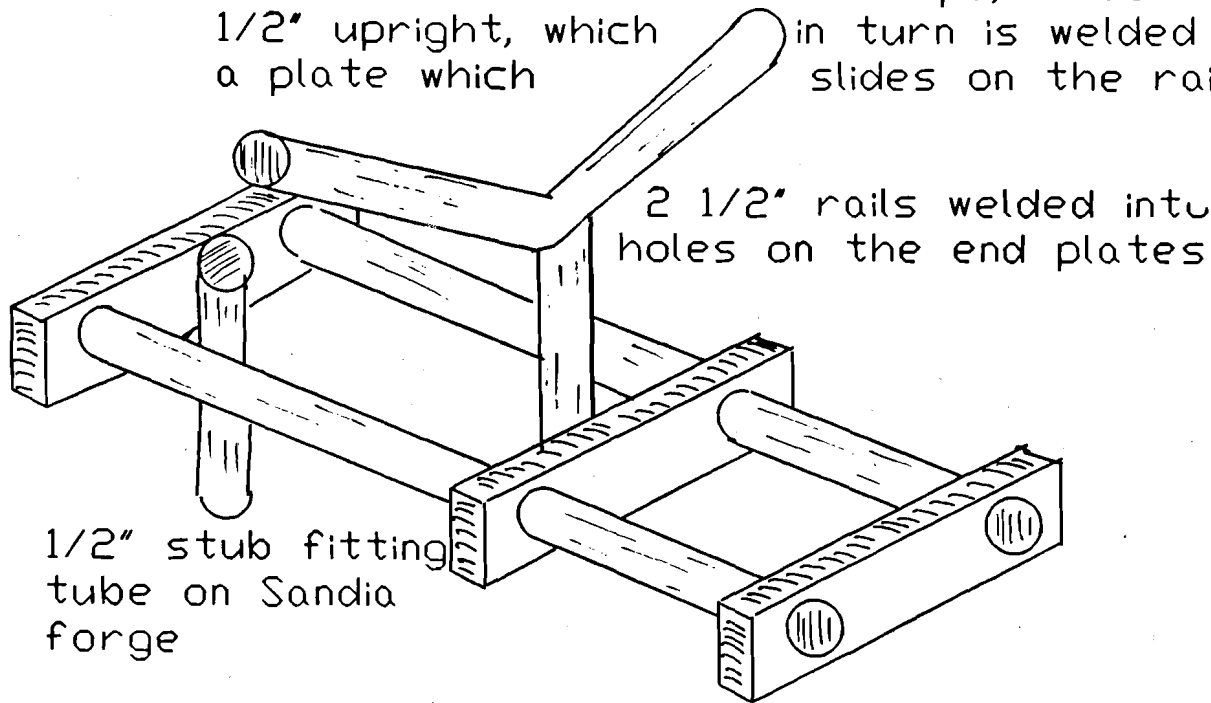

End plates and mobile plate made with 1/2" x 1" x 3" stock, with 2 1/2" holes drilled 2" apart. Holes in mobile plate reamed slightly over 1/2".

Copyright (C) 1993 -- Dr. Stephen A. Bloom

Cup Hook

Steve Bloom

Materials: 20' of 1"x3/16"
12' of 1/2"x1/8"

Mark at 1' and 4' from both ends

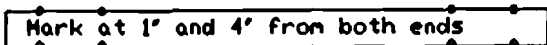

Working on one end at a time...

Draw a point



Spring fuller notches



Draw a taper

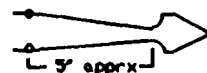

Form a leaf and chisel veins and rib. Shape leaf into a life-like form.

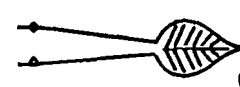

Punch a counter-sink but don't punch all the way through.

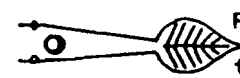

Make a right-angle bend at the 4' marks.

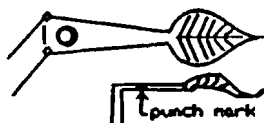

Using the curve former, insert the bend as shown and then pull the stock back into line - forming a pleasing smooth curve.

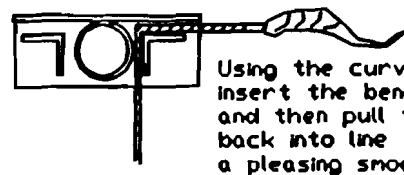



Repeat all steps on the other end of the bar.



Using a bending fork, bend the leaf through 180 degrees, then bend the leaf forward so it lies over the top of the smooth depression but does not block the counter-sink depression. Mirror-image the other leaf.

Jigs:

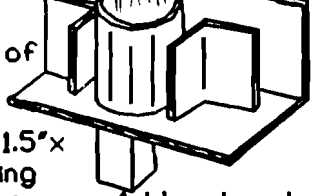
Curve Former: Weld 2 pieces of 1"x1" angle & a section of 1.5" pipe to 5' of 1.5"x1.5" angle, leaving 0.25" between pieces. Add a hardy stub.



Spacer: kink an 8" piece of 1"x1/4" flat stock.

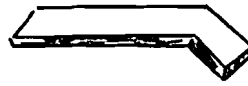

Hook Creation:

Form a finial on a 6" piece of 1/2"x1/8" stock



Form a hook



Fold the rear of the hook through a right angle (take care not to crush the hook)



Use the spacer to close the rear of the hook to a 0.25" gap. Make 2 or 3 such hooks.

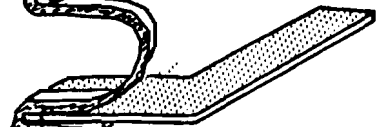

Drill out the mounting holes and use whatever surface treatment you like.

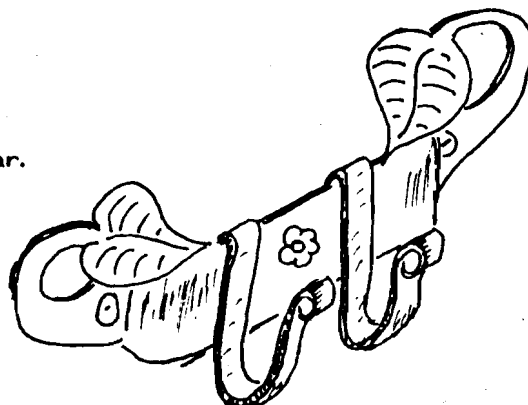

Copyright (C) 1993 -- Dr. Stephen A. Bloom

FOR SALE

METAL LATHE - High quality custom built lathe including compound rest, lead screw, and heavy duty stand complete with leveling feet. This lathe needs new headstock bearings, a motor, and work on the spindle; Engineering drawings are available. The lathe has a 36" bed and approximately a 12" swing. \$70 Pick up in Jacksonville - Bob (904) 260-9735.

CHAMPION LANCASTER BLOWERS (2) - The Lancaster model is the one with the full bell shaped cast iron stand. It's usually used in a permanent shop although it's "portable" if you're strong. One unit is in very good operating condition - everything is in nice shape and its even got a coat of primer on it. (\$100) The other is a project case however all the castings and gears are in perfect condition - it needs some new bushings pressed into the case (\$55) [\$135 for both] Pick up in Jacksonville. Bob (904) 260-9735

Florida Artist Blacksmith Association (FABA)
Chapter of ABANA, Inc.
Star Route 1 Box 207, Crescent City, FL 32112

President (92-93):	Tico Rubio	(904) 749-3327 h;
Vice President (93-94):	J. C. Hawkins	(904) 538-3348 h;
Secretary / Treasurer (92-93):	Roger & Carol Stuart	(904) 467-9031 h;
Newsletter Editors (93-94):	Bob & Donna Jacoby	(904) 260-9735 h;
Program Chair (92-93):	Bill Roberts	(904) 687-2959 h;
Past-President (91-92):	Lewis Riggleman	(904) 521-3515 h; (813) 942-5454 w
Trustee #1 (92-93):	Clyde Payton	(904) 997-3627 h; (904) 488-0577 w
Trustee #2 (93-94):	Pat Imbimbo	(904) 656-3494 h; (904) 488-4891 w
Trustee #3 (92-93):	Carl Austin	(813) 735-0257 h;
Trustee #4 (93-94):	Dale Kipp	(407) 793-0579 h; (407) 694-3779 w
Trustee #5 (92-93):	Steve Bloom	(904) 528-6508 h; (904) 392-7279 w

FABA MEMBERSHIP APPLICATION

Florida Artist Blacksmith Association

Name _____

Address _____

Home Phone _____

Work Phone _____

Spouse's Name _____

Are you interested in procuring:

- Anvil Coal Hand Tools
 Blower Forge Post Vice
 Other

Send this application and membership fee of \$15 (make checks out to FABA) to:

Roger & Carol Stuart, FABA Treasurers
Star Route 1, Box 207
Crescent City, FL 32122

FABA membership includes a one year subscription to *The Florida Clinker Breaker*. Membership year begins May 1; new memberships received after Jan. 31 cover the following membership year. Membership includes your entire family. You don't have to be a member of ABANA to join FABA although we encourage membership in both organizations.

ABANA MEMBERSHIP APPLICATION

Artist Blacksmith Association of North America, Inc.

Name _____

Address _____

Phone _____

I, _____, hereby apply for membership in the Artist blacksmith Association of North America, Inc. and enclose _____ as my annual membership dues. Checks must be US funds and made out to ABANA. Membership includes a one year subscription to *The Anvil's Ring*.

- | | |
|--|-------|
| <input type="checkbox"/> Regular Membership | \$35 |
| <input type="checkbox"/> Full-time Student (one year only) | \$25 |
| <input type="checkbox"/> Family Membership (one vote) | \$40 |
| <input type="checkbox"/> Senior Citizen (over age 65) | \$25 |
| <input type="checkbox"/> Overseas Membership | \$45 |
| <input type="checkbox"/> Contributory Member | \$100 |
| <input type="checkbox"/> Public Library Subscription | \$25 |

Visa / MC: _____ Card #: _____
 Expires: _____
 Signature: _____

Call (812) 988-6919 to charge your membership to Visa/ MC, or make out a check to ABANA and send to:

ABANA
PO Box 1181
Nashville, Indiana 47488